



TP 14509E
(07/2007)

SECOND-CLASS ENGINEER

SET OF SPECIMEN EXAMINATION QUESTIONS



TC-1002397



Canada 

<p>Responsible Authority</p> <p>The Director, Marine Personnel Standards and Pilotage, is responsible for this document, including any change, correction, or updates.</p>	<p>Approval</p> <hr/> <p>“original signed by Naim Nazha”</p> <hr/> <p>Naim Nazha Director, Marine Personnel Standards and Pilotage Marine Safety</p>
---	--

Original Date Issued: December 2005

Date Revised: July 2007

© Her Majesty the Queen in Right of Canada, as represented by the Minister of Transport, 2005.

Permission is granted, by Transport Canada, to copy this TP 14509E as required. While use of this material has been authorized, Transport Canada shall not be responsible for the manner in which the information is presented, nor for any interpretations thereof. This TP 14509E may not be updated to reflect amendments made to the original content. For up-to-date information, contact Transport Canada.

ISBN 978-0-662-46927-8
Catalogue No. T29-25/2007E

TP 14509E
(07/2007)

TC-1002397

DOCUMENT INFORMATION			
Title	SECOND-CLASS ENGINEER – SET OF SPECIMEN EXAMINATION QUESTIONS		
TP No.	TP 14509E	Edition	2
Catalogue No.	T29-25/2007E	ISBN	978-0-662-46927-8 RDIMS : #2529801
Originator	Amir Maan Marine Personnel Standards and Pilotage Tower B, Place de Ville 112 Kent St. 4 th floor Ottawa, ON K1A 0N8	Telephone	(613) 990-2075
		Fax	(613) 990-1538
		E-mail	MarineSafety@tc.gc.ca
		URL	http://www.tc.gc.ca/MarineSafety

REVISION CHART				
Last Review				
Next Review				
Revision No.	Date of Issue	Affected Pages	Author(s)	Brief Description of Change
01	July 2007		Amir Maan	This document is updated taking into account the coming into force of the Canada Shipping Act, 2001.

TABLE OF CONTENTS

1. Scope and Application	1
1.1 Purpose:	1
1.2 Scope:.....	1
1.3 Effective Date:	1
1.4 Authority:.....	1
2. General Information.....	2
3. Applied Mechanics.....	3
4. Thermodynamics	5
5. Technical Drawing.....	7
6. Electrotechnology.....	8
7. Naval Architecture.....	10
8. Engineering Knowledge – General.....	12
9. Engineering Knowledge – Motor.....	14
10. Engineering Knowledge – Steam.....	16

1. SCOPE AND APPLICATION

1.1 PURPOSE:

To provide information to seafarers and marine training institutions by outlining the guidance on the examination for obtaining the certificate of competency as Second-class Engineer, Motor Ship and Second-class Engineer, Steamship.

1.2 SCOPE:

Recommended for all those seafarers who intend to write examinations for the certificate of competency as Second-class Engineer, Motor-Ship and/or Second-class Engineer, Steamship.

1.3 EFFECTIVE DATE:

This document enters into force on July 1st, 2007

1.4 AUTHORITY:

The *Marine Personnel Regulations* (SOR/2007-115), made pursuant to the *Canada Shipping Act, 2001* (2001, c.26).

2. GENERAL INFORMATION

This guide is intended to provide information to the candidates for the Second-class Engineer, Motor Ship and Second-class Engineer, Steamship certificates.

1. You must pass a written examination in each of the following subjects:
 - Naval Architecture
 - Applied mechanics;
 - Thermodynamics;
 - Electrotechnology;
 - Technical Drawing
 - Engineering Knowledge, General;
 - Engineering Knowledge, Motor and/or
 - Engineering Knowledge, Steam.
2. Questions may refer to any of the areas of knowledge mentioned in the syllabus.
3. For each subject, you will be given 9 questions; only 6 must be attempted, excepting Technical Drawing where you will be given a choice of subjects.
4. On completion of the written examinations, you must also pass an oral examination to test your practical knowledge; this examination may include references to the answers given in the written examinations.

Before beginning the written examinations, read carefully the rules on the first page of the Answer Booklet. Any question should be addressed to the Examiner before beginning the examination.

Please visit the following Transport Canada Web sites:

For more information on the general requirements, qualifying service, validity and examination syllabus of the Second-class certificates,

<http://www.tc.gc.ca/marinesafety/TP/TP2293/2293-section-2/section2-chapter27.htm>

For any other question about the Examination and Certification of Seafarers,

<http://www.tc.gc.ca/MarineSafety/TP/TP2293/menu.htm>

3. APPLIED MECHANICS

Time allowed: 3.5 hours

Six (6) questions only to be attempted.

1. A cylinder, a sphere and the base of a cone all have the same diameter. The heights of the cylinder and cone are each equal to the diameter of the sphere. Find the ratio of the volumes of the cylinder and sphere relative to the volume of the cone.
2. Four co-planar forces act at a point O, the values and direction of the forces being as illustrated. Calculate the value and direction of the resultant force.

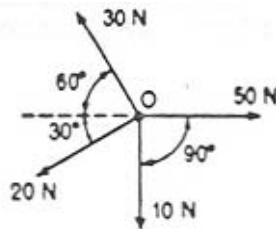

3. On a certain inclined plane, a body which weighs 50 N requires a force of 35 N to pull it up the incline. If the coefficient of friction is 0.25, find the angle of the incline.
4. A motor car is on the verge of skidding when traveling at 48 km/h on a level road around a curvature of 30 m radius. Find the coefficient of friction between the tires and the ground.
5. A solid steel cone, 450 mm diameter at the base and of 600 mm perpendicular height, stands on its base on a level ground. Calculate the joules of work to tilt it until it is on the point of toppling over on to its side. The density of steel is 7.86 g/cm^3 , the position of the centre of gravity of a cone is at one-quarter of its height from the base.
6. A tensile test is performed on a length of wire 2 mm diameter and 4 m long, the following data being observed:

Load [N]	100	200	300	400	500	600
Extension [mm]	0.6	1.2	1.8	2.4	3.0	3.6

Plot a Load-Extension graph and find the modulus of elasticity of the material.

7. An undersea research vehicle has a spherical hull of 1 m radius and 40 mm thickness. The hull is constructed of high strength alloy steel having a yield point of 700 MPa. Neglecting the adverse effect of entrance ports cut into the hull determine the depth the vessel may be submerged to set up a stress equal to that of the yield point.

Note: Relative Density of sea water. = 1.023

8. A steel beam of uniform cross-section is 6.5 m long and weighs 300 N/m of length. There are two supports spaced 5 m apart, one of which is located at the end of the beam. Calculate the load required on the free end to just balance the weight of the beam.

9. A rectangular tank of dimensions: 2 m x 1.4 m x 1 m deep contains fresh water to a depth of 0.6 m. A block of wood of mass 156 kg is then placed so that it floats freely upon the surface of the water. Calculate the load (kN) on the bottom of the tank:
- (i) before the block is placed on the water,
 - (ii) after the block is placed on the water.

4. THERMODYNAMICS

Time allowed: 3.5 hours

Six (6) questions only to be attempted.

1. 15 kg of steel ball bearings at 100°C are immersed in 25 kg of water at 20°C. Assuming no loss of heat to or from the container, calculate the final temperature of the water after equilibrium has been attained.

Note: Specific heat capacity of steel = 0.4857 kJ/ kg/ °K

Specific heat capacity of water = 4.187 kJ/ kg/ °K

2. The steel cables supporting the "Lion's Gate" suspension bridge are approximately 1200 m long. If the temperature ranges from -9°C to 26°C between winter and summer extremes, calculate the variation in the length of the cables.

Note: Coefficient of expansion (steel) = $(12) (10^{-6}) / ^\circ\text{C}$

3. The product storage chamber for a fresh frozen fish plant is 30 m long, 23 m wide and 3 m high. The walls and ceiling are insulated with 25 cm of granulated cork and the floor with 15 cm of cork-board. Calculate the heat transfer per hour due to conduction if the temperature inside the chamber is kept at -30°C and the ambient air temperature outside is 21°C. The ground temperature may be taken as 10°C.

Note: λ (cork-board) = 0.043 W/ mK

λ (granulated cork) = 0.049 W/ mK

$$Q = \frac{\lambda A t \Delta T}{L}$$

4. (i) Derive the characteristic gas equation, $PVT^{-1} = mR$
(ii) A quantity of gaseous oxygen has a volume of 250 cm³ at 15°C and a pressure of 774 mm Hg. Calculate the volume of this gas at Standard Temperature and Pressure (S.T.P.), that is at 0°C and 760 mm Hg.
5. An inventor claims to have developed an engine which receives 105 500 kJ of energy from the fuel supply, rejects 26 375 kJ to the exhaust, and delivers 25 kWh of mechanical work. Would you advise investing money to place this engine on the market?
6. The following results were obtained during the trial of a single cylinder, four-stroke, diesel engine of cylinder bore 200 mm and stroke 400 mm:

Effective brake wheel diameter = 1.6 m

Speed = 258 rev/min

Effective brake load = 47 kg

Area of indicator diagram = 320 mm²

Spring No. 110 kPa per mm

Length of diagram = 65 mm

Fuel consumption = 3.2 kg/h

Calorific value of fuel = 45 MJ/kg

Cooling water supplied = 2.3 kg/min

Temperature rise of cooling water = 38°C

Calculate:

- (i) Mechanical efficiency
- (ii) Indicated thermal efficiency
- (iii) Draw up an energy balance account on a basis of 1 minute.

7. Air is taken into a single-stage air compressor at 1 bar and delivered at 5 bar. The piston swept volume is 1440 cm³ and the clearance volume is 40 cm³. Taking the index of compression and expansion as 1.3, calculate

- (i) the fraction of the stroke when the delivery valves open,
- (ii) the fraction of the stroke when the suction valves open,
- (iii) the mean indicated pressure. Note, the area under a p V' curve is :

$$\frac{p_1 V_1 - p_2 V_2}{n - 1}$$

8. (i) Sketch an indicator diagram (PV diagram) for a steam engine showing the way in which **cut-off governing** alters the size of the diagram.
- (ii) Sketch an indicator diagram (PV diagram) for a steam engine showing the way **throttle governing** alters the size of the diagram.
- (iii) A single cylinder steam engine rotates at 3.5 revolutions /second, has a cylinder diameter of 200 mm and a stroke of 300 mm. If the mean effective pressure is 510 kPa, calculate the indicated power.

9. A boiler initially contains 4 t of water at 80 p.p.m. (parts per million). If the evaporation rate is 500 kg/h and the feed water contains 150 p.p.m. of dissolved solids calculate:

- (i) the density (p.p.m.) of the boiler water after 12 hours
- (ii) the time for the water to reach 2000 p.p.m. from the time of initial condition.

5. TECHNICAL DRAWING

Time allowed: 6 hours

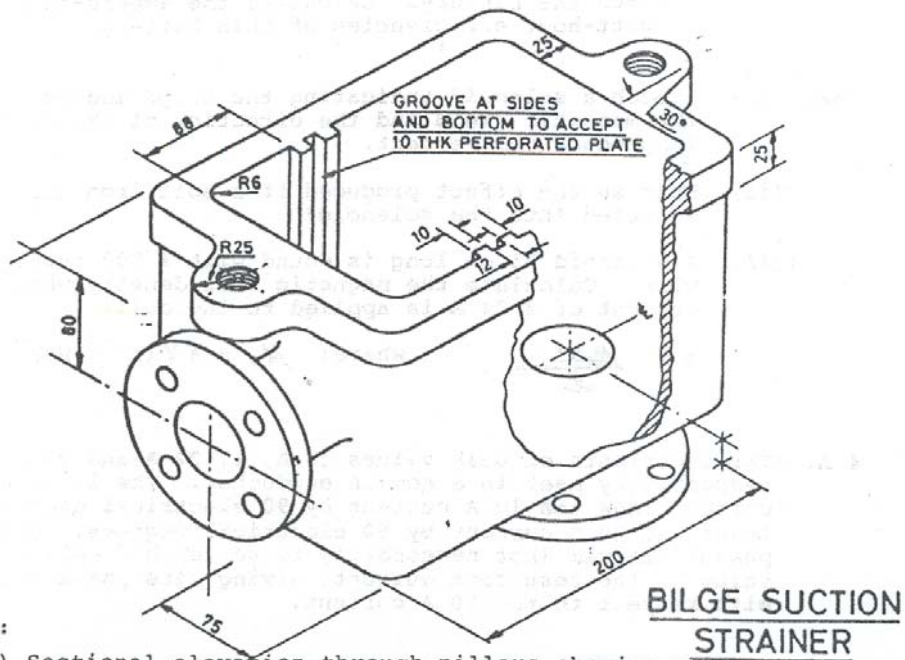
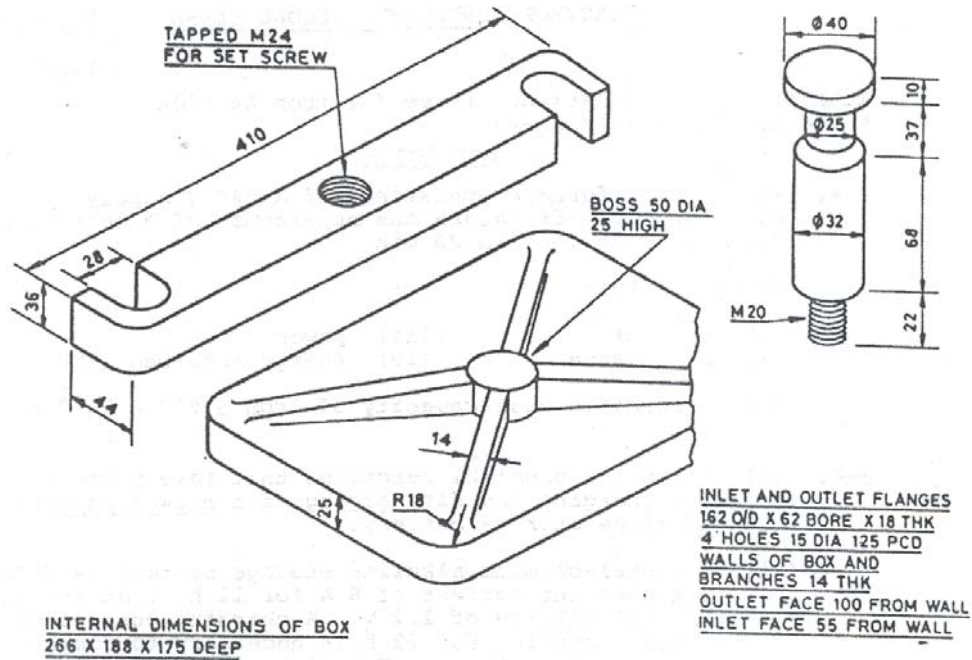

DRAW:

- (i) Sectional elevation through pillars showing all parts assembled.
- (ii) End Elevation
- (iii) Plan View

6. ELECTROTECHNOLOGY

Time allowed: 3.5 hours

Six (6) questions only to be attempted.

1. An electric furnace operating off a 240 V supply with an efficiency of 76% raises the temperature of 3 kg of iron from 16°C to 750° in 20 min. Calculate the:

- (i) current (iii) power
(ii) resistance (iv) energy absorbed (kWh)

Note: Specific heat capacity of iron = 500 J/ kg/ °K

2. (i) State the chemical reactions that take place during the charging and discharging of a nickel-cadmium alkaline storage battery.
(ii) A nickel-cadmium alkaline storage battery is discharged at a constant current of 6 A for 12 h at an average terminal voltage of 1.2 V. A charging current of 4 A at 1.5 V applied for 22 h is necessary to completely recharge the battery. Calculate the ampere-hour and the watt-hour efficiencies of this battery.
3. (i) Sketch a solenoid indicating the shape and polarity of the magnetic field and the direction of the current to produce this effect.
(ii) What is the effect produced if a soft iron core is inserted into the solenoid?
(iii) A solenoid 75 cm long is wound with 4 000 turns of wire. Calculate the magnetic flux density when a current of 2.84 A is applied to the coil.

$$B = \frac{\mu_0 NI}{\ell} \quad \text{where: } \mu_0 = 4\pi (10^{-7}) \text{ Wb/ A/ m}$$

4. Three currents of peak values 10 A, 17.32 A and 20 A respectively meet in a common conductor. The 17.32 A current lags the 10 A current by 90 electrical degrees and leads the 20 A current by 60 electrical degrees. Draw a phasor diagram (not necessarily to scale) and calculate the value of the resultant current, giving its phase relation with respect to the 10 A current.
5. A ship's electrical service supplied 100 KVA at 440 V and 60 Hz to an induction motor with an inductance of 1 H and an ohmic resistance of 350 Ω . Calculate the:
- (i) inductive reactance of the motor
(ii) impedance
(iii) current supplied to the motor
(iv) power factor
(v) power input to the motor (kW)
(vi) size of capacitor (μ F) required in the circuit to raise the power factor to 95%

6. Sketch and describe a Synchroscope used when paralleling two 3-phase alternators.
State all the precautions to be taken while paralleling two alternators.
7. Sketch a switchboard for controlling and monitoring of the performance of two-three (3) phase alternators that may be arranged for parallel operation. Your sketch should include all the necessary meters, instruments, regulators, circuit breakers and other protective devices required for controlling of the machines.
8. Describe the STAR-DELTA type of starter for a large squirrel cage induction motor. What is the advantage of this method of starting over direct on line starting?
9. Sketch and describe an electric brake for a cargo winch. What care and attention does it require for safe and efficient operation? How the winch and crew operating the winch is protected in case of power failure while winch is operating on load?

7. NAVAL ARCHITECTURE

Time allowed: 3.5 hours

Six (6) questions only to be attempted.

1. A ship of 137.2 m length, 14.6 m beam, 6.4 m draught 9200 t displacement has a Water Plane Area of 1607 m² and an immersed mid-ship sectional area of 84.7 m². Calculate the:

- (i) block coefficient
- (ii) prismatic coefficient
- (iii) coefficient of water plane area
- (iv) coefficient of immersed mid-ship section

Assume the relative density of sea water = 1.025

2. A ship 140 m long and 18 m beam floats at a draught of 9 m. The immersed cross-sectional areas at equal intervals are : 5; 60; 116; 145; 152; 153; 153; 151; 142; 85; and 0 m² respectively. Calculate the:

- (i) displacement
- (ii) block coefficient
- (iii) mid-ship section area
- (iv) prismatic coefficient

Assume the relative density of sea water = 1.025 t/m³.

3. (i) Describe how an inclining experiment is carried out.
(ii) During such an experiment, a vessel of 8 000 t displacement was inclined by moving a mass of 5 t a distance of 12 m transversely across the deck. A pendulum 6 m long was used and the following deflections recorded: 80, 84, 82, 86 mm. If the distance from the keel to the metacentre is 5.1 m, calculate the distance from the keel to the centre of gravity of the ship.
4. In a towing tank experiment a thin plate was pulled through the water at a velocity of 3.5 m/s and found to have a frictional resistance of 16 Pa, the speed index being 1.97.

A ship 350 m long, 50 m beam, 19.5 m draught has a block coefficient of 0.89. If the total frictional resistance of the vessel is 2 800 kN, calculate the speed of the ship.

Note: 1 nautical mile = 1852 m

$$S = 1.7 Ld + \frac{\nabla}{d}$$

Where: S = wetted surface (m²)

L = length (m)

D = draught (m)

∇ = displacement volume (m³)

5. A four (4) bladed 3810 mm diameter propeller with a boss or hub of 530 mm diameter, and each blade has a face area of 0.900 m^2 . The propeller pitch is 3.300 m and when the shaft turns 98 revolutions/minute the ship travels at the rate of 9.3 knots. Calculate:
 - (i) the ratio of blade face area to disc area
 - (ii) the percentage slip
6. Sketch a longitudinal section of either an oil tanker or a container ship showing all the scantlings. Explain the important structural features of the particular type you have selected.
7. Sketch the GREAT LAKES LOAD LINE markings placed upon the side of a ship. How and in what manner do the assigning authorities prevent these marks from being changed? Is there any allowance for different waters and different seasons of the year? .
8. Sketch the forward or front bulkhead of a bridge or deck-house structure indicating the method by which it is attached to the deck, bulwark and bridge side plating. What provision is made for the sudden break *in* strength (discontinuity) at the junction of deck-house and bulwark?
9. Sketch a method employed to fasten an Aluminum deck-house to a steel deck indicating any unusual or peculiar precautions required to mitigate the corrosion problem.

8. ENGINEERING KNOWLEDGE – GENERAL

Time allowed: 3.5 hours

Six (6) questions only to be attempted.

1. Sketch and describe a self-cleaning centrifugal purifier. How would you convert a purifier into clarifier. Enumerate the routine maintenance you will carry out to have trouble free operation.
2.
 - (i) Discuss the merits and demerits of using roller bearings for the main propulsion shafting.
 - (ii) Why are roller bearings seldom used with the propeller shaft itself?
 - (iii) Why are fitted bolts used in the couplings connecting the lengths of propulsion shafting together?
3. With the aid of suitable sketches discuss the function, importance, or operation of the following arrangements or devices fitted to steering gear.
 - (i) overhead oil tank
 - (ii) relief valves
 - (iii) hunting gear
 - (iv) end stoppers to rudder movement
4.
 - (i) Sketch a multi flow type of shell and tube type of lubricating oil cooler indicating the direction of flow of oil and coolant.
 - (ii) Name the materials used for the various components.
 - (iii) What major faults are likely to arise with this equipment?
 - (iv) How are these faults inhibited?
5.
 - (i) Draw a line diagram of a freon refrigerator cycle and indicate the operating pressures and temperatures and explain how different temperatures are maintained for meat, vegetable and dairy products.
 - (ii) Detail the position of automatic condition (temperature) sensing devices and explain how these operate to control the running of the machine.
6.
 - (i) Sketch an automatically operated modern oily water separator.
 - (ii) Describe how it works.
 - (iii) What routine care and attention is required in order to maintain satisfactory performance?
7.
 - (i) Draw a line diagram of a bilge pumping system for a container ship.
 - (ii) Indicate the position and the type of valves fitted to ensure satisfactory operation of the system.
 - (iii) What arrangements are provided to ensure--the integrity of the system should collision damage occur?

8. Enumerate the safe practices to be adhered to when personnel are:
 - (i) dismantling machinery during rough weather conditions.
 - (ii) replacing jointing or overhauling valves in steam lines.
 - (iii) working in double-bottom tanks.
 - (iv) lifting heavy loads manually, and with lifting tackle.

9. Describe an electrical bridge-engine room telegraph. How does the "wrong way" alarm operate?

9. ENGINEERING KNOWLEDGE – MOTOR

Time allowed: 3.5 hours

Six (6) questions only to be attempted.

1. State the reasons for the following turbo-charger abnormalities and the steps taken to avoid such occurrence:
 - (i) unusually low discharge air pressure
 - (ii) unusually high discharge air pressure
 - (iii) excessive vibration when operating at normal speed

2. Explain how the power developed by an engine is effected by the following conditions:
 - (i) worn piston rings and cylinder liners
 - (ii) insufficient clearance between the cylinder valve cams and their followers
 - (iii) leaking fuel pump spill valves

3. Describe with the aid of a sketch a high-pressure jerk type of fuel pump suitable for a slow speed diesel engine. How the beginning and end of injection is controlled in this pump.

4.
 - (i) Draw a line diagram of a complete lubricating oil system for a two stroke medium speed Main Engine.
 - (ii) Explain why a large quantity of oil is kept in reserve.
 - (iii) Explain why both lubricating oil filters and centrifugal purifiers are fitted.

5.
 - (i) Describe the treatment given to the main engine cooling water to maintain it in acceptable condition.
 - (ii) Why is such treatment necessary?
 - (iii) Name the chemicals most generally used and the manner in which they produce the desired effects.

6.
 - (i) State two good reasons why heavy residual fuel oil is heated before being injected into a diesel engine.
 - (ii) What effect will excessive heating of the fuel have on the engine performance?
 - (iii) What precautions must be taken before manoeuvring an engine that is operating on this heavy residual fuel and has to be changed to diesel oil?

7. The boiler used to supply the heating steam for a motor ship is found to show no water level in the gauge glass.
 - (i) Describe the action you would take to rectify this situation.
 - (ii) Describe any fault you may have discovered in the automatic boiler control system which may have precipitated the problem and how it was rectified.

8.
 - (i) Describe with the aid of a sketch the arrangements used to ensure that the engine cannot be operated in contradiction of the bridge telegraph order.
 - (ii) Some engines may continue to operate in the ahead direction after the controls have been placed in the astern position. Describe the arrangements fitted to prevent such an occurrence.

9. Discuss each of the following factors in relation to scavenge-space fires:
 - (i) primary cause of such fires
 - (ii) effect upon the engine operation
 - (iii) manner in which the fire may be dealt with
 - (iv) manner in which such fires may be avoided

10. ENGINEERING KNOWLEDGE – STEAM

Time allowed: 3.5 hours

Six (6) questions only to be attempted.

1.
 - (i) Sketch and describe the arrangement and purpose for
 - (a) roof firing, and
 - (b) tangential firing, in power boilers.
 - (ii) Explain how each development has effected boiler design.
 - (iii) What are the merits and demerits of each arrangement?
2. In order to mitigate the problems arising from the use of boiler feed water containing inorganic salts causing the so called "permanent" or non-carbonate hardness, it has become standard practice to use some type of phosphate compound.
 - (i) Describe the manner in which the phosphate operates to prevent scale formation stating the chemical reaction involved.
 - (ii) What prevents the reaction products from precipitating and forming scale on the heating surfaces?
 - (iii) What measures are used to control the amount of chemical used?
 - (iv) Is this type of treatment considered satisfactory with a very high pressure boiler? If not, why not? What other chemicals would likely be used?
3.
 - (i) With the aid of a block diagram, describe the instrumentation required for the automatic operation of a power boiler.
 - (ii) What factors must be considered for the satisfactory operation of such a system?
4. With reference to feed water heaters discuss.
 - (i) the detection and result of tube leakage,
 - (ii) the reasons for air venting and how this is accomplished,
 - (iii) the reasons for using multi-stages and the consequent plant arrangement for maximum efficiency,
 - (iv) the use of bled steam and exhaust steam.
5. Sketch and describe a main condensate extraction pump.
Describe the arrangements provided to:
 - (i) prevent air entering the feed system through the pump.
 - (ii) ensure the pump operates effectively at condenser pressure.
 - (iii) ensure the pump operates effectively at light boiler loads.
6. Sketch and describe a multistage flash evaporator for producing fresh water from sea water. How steam can be used to produce fresh water on board? Discuss merits and demerits of producing water by this method.
7.
 - (i) Sketch and describe a spray type of deaerator designed for marine applications.
 - (ii) Why is such a device used?
 - (iii) Why is the temperature of the water within the deaerator so important?

- (iv) Where is the deaerator usually located and why is it placed in this position?
- 8.
- (i) Give at least two reasons for loss of vacuum in a main condenser.
 - (ii) Describe how you would trace the cause of the trouble.
 - (iii) Why is it considered poor practice to operate the main turbine with a reduced condenser vacuum except possibly for a short period?
- 9.
- (i) Sketch and describe the arrangement employed to counteract the problem of hydraulic thrust in a turbo-feed pump.
 - (ii) How is this type of feed pump protected under light load conditions?
 - (iii) What safety devices are required for the safe operation of a turbo-feed pump?